

KOMATSU

PC360LCi-11 PC360NLCi-11



Hydraulic excavator



Engine power

202 kW / 271 HP @ 1950 rpm

Operating weight

PC360LCi-11: 35900 - 36850 kg
PC360NLCi-11: 35770 - 36530 kg

Bucket capacity

max. 2.66 m³

PC360LC/NLCi-11



Save time

Reduce staking, grading and inspection with 3D design data and semi-automatic grading.



Increase productivity

Using semi-automatic intelligent Machine Control versus manual machine guidance.



Lower costs

Through fewer bucket cycles, reduced machine movements and eliminated rework.



Engine power
202 kW / 271 HP @ 1950 rpm

Operating weight
PC360LCi-11: 35900 - 36850 kg
PC360NLCi-11: 35770 - 36530 kg

Bucket capacity
max. 2.66 m³

Transform your job sites with advanced automation



Powerful and environmentally friendly

- EU Stage V engine
- Komatsu Integrated Attachment Control (KIAC) (option)
- Adjustable idle shutdown
- Komatsu fuel-saving technology

First-class comfort

- Fully air-suspended operator station
- Low-noise design
- Widescreen monitor



Intelligent Machine Control 2.0

- Fully field-proven automated digging control
- Bucket angle hold feature
- Auto Tilt Control for tilt bucket
- IMU sensor for tilt bucket integration
- Intelligent, compact touch screen monitor
- Fully factory-integrated solution

Safety first

- Komatsu SpaceCab™
- KomVision surround view system
- Neutral position detection system

Quality you can rely on

- Komatsu-quality components
- Extensive dealer support network

Komtrax

- Komatsu Wireless Monitoring System
- 4G mobile communications
- Integrated communication antenna
- Operational data and reports



A maintenance program
for Komatsu customers

PC360LC/NLCi-11



Innovative

The PC360LC/NLCi-11 with intelligent Machine Control 2.0 (iMC 2.0) provides even greater productivity gains for the customer. The renowned accuracy and automatic grading is enhanced with new features increasing ease of operation and finished quality, and reducing cycle times.

Intelligent

The Komatsu PC360LC/NLCi-11 intelligent Machine Control excavator lets you focus on moving material efficiently, with no worry about digging too deep. The new iMC 2.0 features mean operations are completed quicker, more accurately and with reduced costs.

Greatly improved efficiency

Komatsu iMC 2.0 makes work even quicker and easier. The automatic features let the operator relax and focus on productivity, with no worry about overdigging. With Auto Grade Assist and Auto Tilt Control the PC360LC/NLCi-11 keeps the bucket edge on the grade and increases bucket fill factors.

Intelligent Machine Control 2.0



Auto Tilt Control

The new iMC 2.0 Auto Tilt Control automatically tilts the bucket to design and returns it to horizontal to unload. Makes delivering final grade quicker and easier.

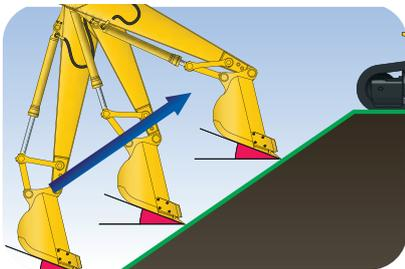

Bucket angle hold feature

Operator selects desired bucket angle and the system maintains bucket angle through grading pass. Vastly increases ease of operation on final grading and trimming work.



Automatic real time digging control

Komatsu intelligent Machine Control is based on Komatsu's unique sensor development, stroke sensing hydraulic cylinders and IMU sensor. You will no longer worry about over digging. When your bucket hits the target surface, the control function automatically limits and maintains grade with real-time bucket edge positioning.



Finger tip control

New lever functions allow the operator to raise or lower the design off-set at the touch of a button. Right lever trigger switch activates/deactivates semi-auto mode. Operator friendly and easy to use.



Intelligent touch screen monitor

The all new 10,4" touch screen monitor features accurate display of machine and design. Operators can customise the split screen views to suit what they want to focus on. And easy multi-touch navigation always provides them with real time digging and grading information.

Komatsu iMC 2.0
makes your work even
quicker and easier.



Intelligent Machine Control 2.0

Integrated – Factory installed components

The intelligent Machine Control system is fully factory-integrated. Komatsu's unique stroke sensing cylinders for boom, arm, bucket and tilt bucket provide real time bucket tip positioning. Combined with built-in IMU sensor and GNSS antennae, the PC360LC/NLCi-11 can achieve incredibly accurate performance, consistently.



SMART CONSTRUCTION Remote

Smart Construction Remote is an optional software solution that enables to remotely send and update design plans even when the machine is offline. It also supports your operators remotely with shared screen control. Does an operator have an issue? Spare yourself that trip to the machine and resolve the problem from home, your office, or another jobsite. Smart Construction Remote works on our very own Komatsu iMC machines and several After Market GNSS systems powered by Windows and Android.

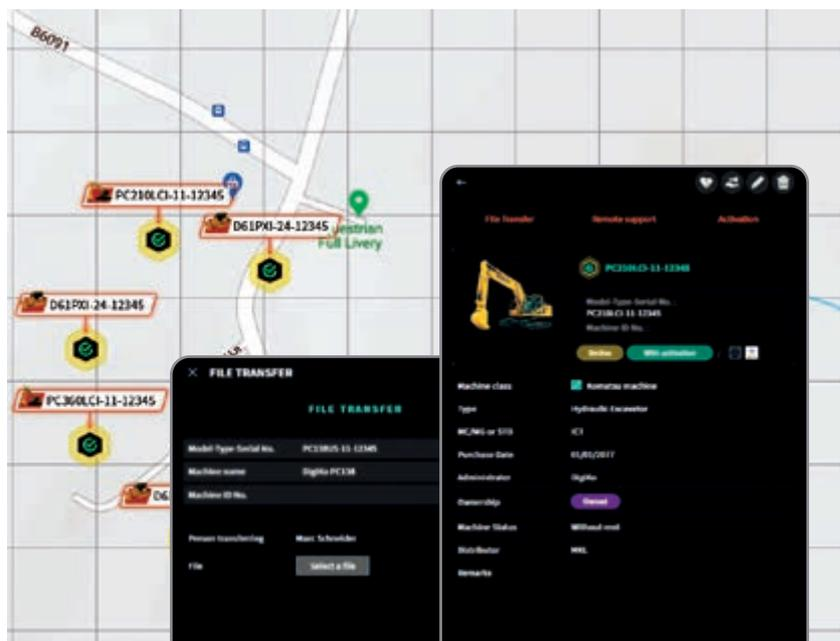

For further information on Smart Construction Remote please check out smartconstruction.io



Higher productivity

The PC360LC/NLCi-11 is quick and precise. It features a powerful Komatsu EU Stage V engine, Komatsu's Closed Center Load Sensing (CLSS) hydraulic system and first-class Komatsu comfort to provide a fast response and unrivalled productivity for its class.

Komatsu fuel-saving technology

With enhanced engine management the PC360LC/NLCi-11 is optimised for low fuel consumption. The variable speed matching of the engine and hydraulic pumps guarantee efficiency and precision during single and combined movements.

Adjustable idle shutdown

The Komatsu auto idle shutdown automatically turns off the engine after it idles for a set period of time. This feature can easily be programmed from 5 to 60 minutes, to reduce unnecessary fuel consumption and exhaust emissions, and to lower operating costs. An Eco-gauge and the Eco guidance tips on the cab monitor further encourage efficient operations.

Powerful and environmentally friendly

Komatsu EU Stage V

The Komatsu EU Stage V engine is productive, dependable and efficient. With ultra-low emissions, it provides a lower environmental impact and a superior performance to help reduce operating costs and lets the operator work in complete peace of mind.

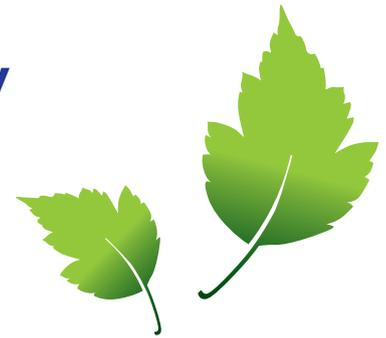

Heavy-duty aftertreatment

The aftertreatment system combines a Komatsu Diesel Particulate Filter (KDPF) and Selective Catalytic Reduction (SCR). The SCR injects the correct amount of AdBlue® into the system at the proper rate to break down NOx into water (H₂O) and non-toxic nitrogen gas (N₂). NOx emissions are reduced by 80% vs. EU Stage IIIB engines.

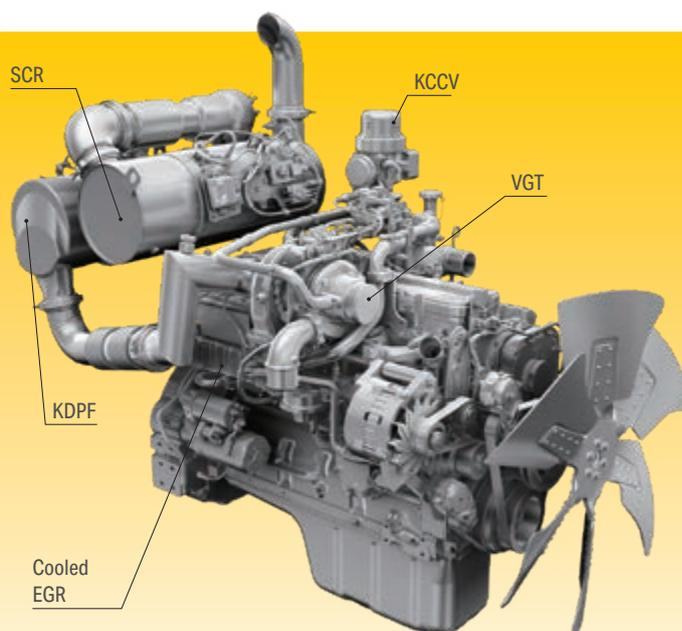
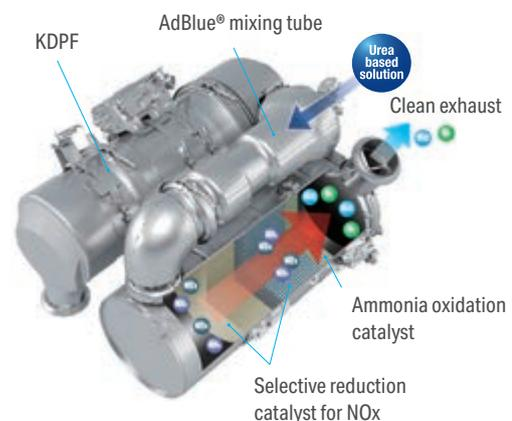

High-Pressure Common Rail (HPCR)

Cooled EGR is a technology well-proven in current Komatsu engines. The increased capacity of the EGR cooler now ensures very low NOx emissions and a better engine performance.

Exhaust Gas Recirculation (EGR)

To achieve complete fuel burn and lower exhaust emissions, the heavy-duty High-Pressure Common Rail fuel injection system is computer controlled to deliver a precise quantity of pressurised fuel into the redesigned engine combustion chamber by multiple injections.

Komatsu Closed Crankcase Ventilation (KCCV)

Crankcase emissions (blow-by gas) are passed through a CCV filter. The oil mist trapped in the filter is returned back to the crankcase while the filtered gas is returned to the air intake.

Variable Geometry Turbo (VGT)

The VGT provides optimal airflow to the engine combustion chamber under all speed and load conditions. Exhaust gas is cleaner, fuel economy is improved while machine power and performance are maintained.

First-class comfort

Enhanced work environment

Designed to prioritise both productivity and operator well-being, the Komatsu crawler excavator cab features thoughtful ergonomics with high-visibility handrails, and improved interior LED lighting. Stepping inside reveals a sleek, dark colour scheme complemented by an effortlessly cleanable floor mat. Upgraded UV-protective tint on the cab rear window minimises sun exposure and helps maintain a cool working environment.

Future-proof customisable workspace

The operator cab offers extensive customisation possibilities. A multi-functional utility bar allows for adding personal accessories such as additional monitors or tablets, while dual USB ports (USB-A & USB-C) enable mobile device charging.



Convenient and secure entry to the spacious, well-insulated, low-noise cab



Multi-functional utility bar (items shown are for illustrative purposes only)



Optional premium seat with top quality cushioning, auto weight adjustment, lumbar support, climate control system, available with optional multi-position armrests and ergonomic control levers



Safety first

Optimal jobsite safety

Safety features on the Komatsu PC360LC/NLCi-11 comply with the latest industry standards and work in synergy to minimise risks to people in and around the machine. A neutral detection system for travel and work equipment levers increase jobsite safety, along with a seat belt caution indicator and an audible travel alarm. Highly durable anti-slip plates – with additional high friction covering – maintain long term traction performance.



Higher safety with iMC

Staking, surveying and final inspection were usually done manually. The PC360LC/NLCi-11 reduces or eliminates the need for ground staff around the machine. GNSS antennae integrated in the handrails remove the need to access the top of the counterweight.



Komatsu SpaceCab™

The ROPS cab has a tubular steel frame and provides high shock absorbency, impact resistance and durability. The seat belt is well designed to keep the operator in the safety zone of the cab in the event of a rollover. Optionally the cab can be fitted with a Falling Object Protective System (FOPS) with openable front guard.



KomVision

KomVision machine visibility gives the operator a constant clear view of the safety zone around the machine. This allows the operator to focus on the work at hand even in low light conditions. With KomVision, various camera view options are available whilst maintaining constant "bird's-eye view" from above the machine



An evolutionary interface

Helpful information is now easier than ever to find and understand with the upgraded monitor interface. An optimal main screen for the ongoing work can be selected simply by pressing the F3 key.

Lower operating costs

Komatsu ICT contributes to the reduction of operating costs by assisting to comfortably and efficiently manage operations. It raises the level of customer satisfaction and the competitive edge of our products.

Widescreen monitor

Installed with a choice of 26 languages, the widescreen monitor with simple switches and multifunction keys gives fingertip access to a large range of functions and operating info.



Eco-gauge, Eco guidance and fuel consumption gauge



Fuel consumption history



ECO guidance record

Information & communication technology



Knowledge

You get quick answers to basic and critical questions about your machines – what they're doing, when they did it, where they're located, how they can be used more efficiently and when they need to be serviced. Performance data is relayed by wireless communication technology (satellite, GPRS or 4G depending on model) from the machine to a computer and to the local Komatsu distributor – who's readily available for expert analysis and feedback.

Convenience

Komtrax enables convenient fleet management on the web, wherever you are. Data is analysed and packaged specifically for effortless and intuitive viewing in maps, lists, graphs and charts. You can foresee eventual maintenance issues and required spare parts, and troubleshoot a problem before Komatsu technicians arrive on site.



The way to higher productivity

Komtrax uses the latest wireless monitoring technology. Compatible on PC, smartphone or tablet, it delivers insightful and cost saving information about your fleet and equipment, and offers a wealth of information to facilitate peak machine performance. By creating a tightly integrated web of support it allows proactive and preventive maintenance and helps to efficiently run a business.

Power

The detailed information that Komtrax puts at your fingertips 24 hours a day, 7 days a week gives the power to make better daily and long-term strategic decisions – at no extra cost. Problems can be anticipated, maintenance schedules customised, downtime minimised and machines kept where they belong: working on the jobsite.



Easy maintenance

Central service points

Komatsu designed the PC360LC/NLCi-11 with centralised and conveniently located service points to make necessary inspections and maintenance quick and easy.

Komatsu Care

Komatsu Care is a maintenance program that comes as standard with your new Komatsu machine. It covers factory-scheduled maintenance, performed with Komatsu Genuine parts by Komatsu-trained technicians. Depending on your machine's engine, it also offers extended coverage of the Komatsu Diesel Particulate Filter (KDPF), and of the Selective Catalytic Reduction (SCR). Please contact your local Komatsu distributor for terms and conditions.

Safe maintenance

Thermal guards around high temperature areas of the engine, protected fan belt and pulleys, a pump/engine partition that prevents hydraulic oil from spraying onto the engine, and exceptionally sturdy handrails: in Komatsu tradition, the highest safety level is provided for fast and smooth maintenance.

Long-life oil filters

The Komatsu Genuine hydraulic oil filter uses high-performance filtering material for long replacement intervals, which significantly reduces maintenance costs.

Flexible warranty

When you purchase Komatsu equipment, you gain access to a broad range of programmes and services that have been designed to help you get the most from your investment. For example, Komatsu's Flexible Warranty Programme provides a range of extended warranty options on the machine and its components. These can be chosen to meet your individual needs and activities. This programme is designed to help reduce total operating costs.



Basic maintenance screen



Aftertreatment device regeneration screen for the KDPF



For simple access, the AdBlue® tank is installed on the front stairway.



Quality you can rely on

Komatsu-quality

With the latest computer techniques and a thorough test programme, Komatsu produces equipment to meet your highest standards. All major components of the PC360LC/NLCi-11 are designed and directly manufactured by Komatsu, and essential machine functions are perfectly matched for a highly reliable and productive excavator. Each and every PC360LC/NLCi-11 undergoes additional system calibration and accuracy tests before delivery, to ensure optimum performance in line with strict Komatsu Engineering Standards.

Rugged design

Maximum toughness and durability are the cornerstones of Komatsu's philosophy – along with safety and top class customer service. Single piece plates and castings are used in key areas of the machine's structure for good load distribution. Highly durable rubbing strips on the underside of the arm protect the structure against impact damage.

Extensive support network

The extensive Komatsu distribution and dealer network is standing by to help keep your fleet in optimum condition. Customised servicing packages are available, with express availability of spare parts, to make sure that your Komatsu equipment continues to perform at its peak. Highly trained and dedicated Technical Support Engineers are always available to ensure intelligent Machine Control performance is maintained.

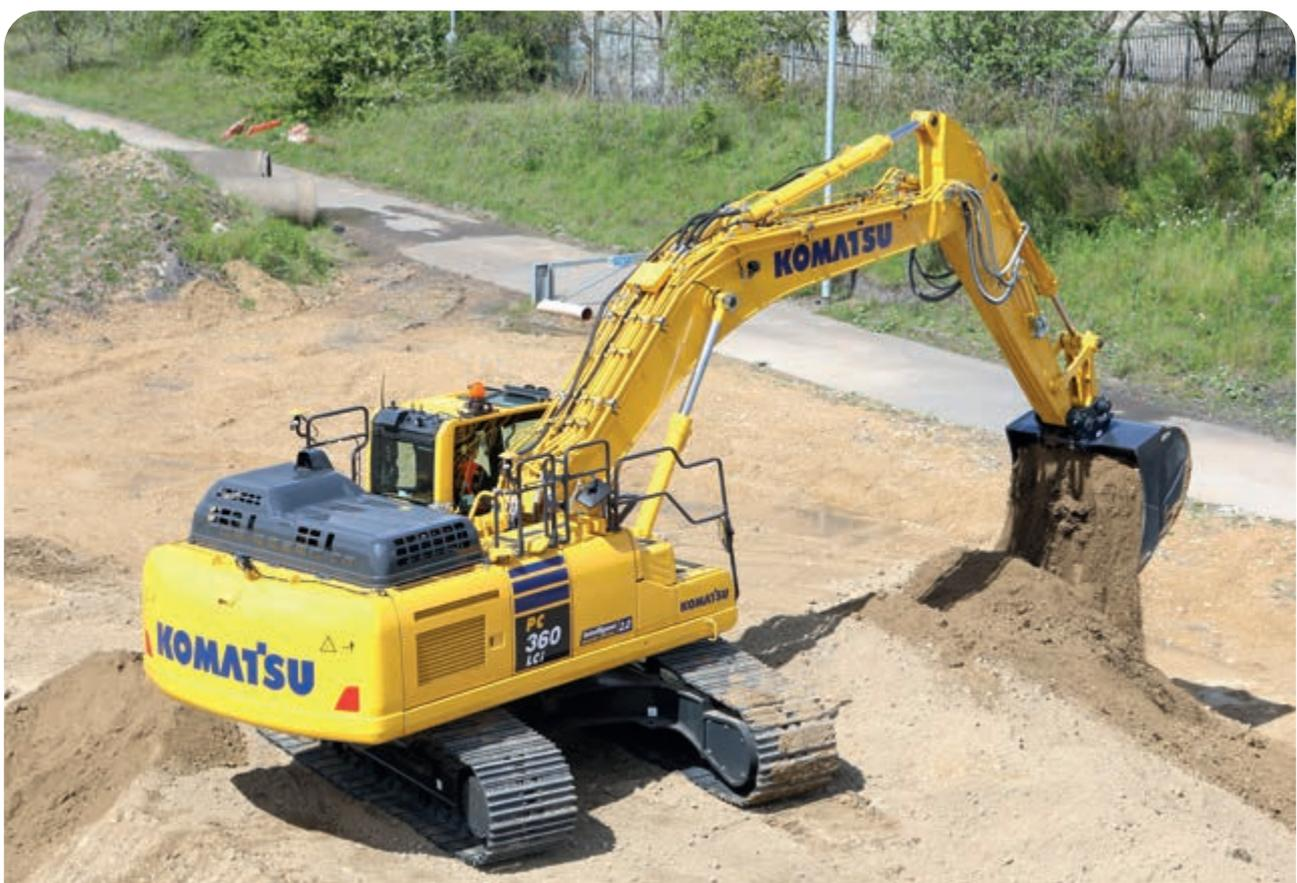

Specifications

Engine

Model	Komatsu SAA6D114E-6
Type	Common rail direct injection, water-cooled, emissionised, turbocharged, after-cooled diesel
Engine power	
at rated engine speed	1950 rpm
ISO 14396	202 kW / 271 HP
ISO 9249 (net engine power)	192 kW / 257 HP
No. of cylinders	6
Bore × stroke	114 × 144.5 mm
Displacement	8.85 l
Air filter type	Double element type with monitor panel dust indicator and auto dust evacuator
Cooling	Suction type cooling fan with radiator fly screen
Fuel	Diesel fuel, conforming to EN590 Class 2/Grade D. Paraffinic fuel capability (HVO, GTL, BTL), conforming to EN 15940:2016

Hydraulic system

Type	HydrauMind. Closed-centre system with load sensing and pressure compensation valves
Additional circuits	2 additional circuits with proportional control can be installed
Main pump	2 variable displacement piston pumps supplying boom, arm, bucket, swing and travel circuits
Maximum pump flow	2 × 267.5 l/min
Relief valve settings	
Implement	380 kg/cm ²
Travel	380 kg/cm ²
Swing	295 kg/cm ²
Pilot circuit	33 kg/cm ²

Service refill capacities

Fuel tank	605 l
Radiator	37 l
Engine oil	38.5 l
Swing drive	14 l
Hydraulic tank	188 l
Final drive (each side)	9.0 l
AdBlue® tank	39 l

Swing system

Type	Axial piston motor driving through planetary double reduction gearbox
Swing lock	Electrically actuated wet multidisc brake integrated into swing motor
Swing speed	0 - 9.5 rpm
Swing torque	103 kNm

Drives and brakes

Steering control	2 levers with pedals giving full independent control of each track
Drive method	Hydrostatic
Travel operation	Automatic 3-speed selection
Gradeability	70%, 35°
Max. travel speeds	
Lo / Mi / Hi	3.2 / 4.5 / 5.5 km/h
Maximum drawbar pull	29570 kg
Brake system	Hydraulically operated discs in each travel motor

Undercarriage

Construction	X-frame centre section with box section track frames
Track assembly	
Type	Fully sealed
Shoes (each side)	49
Tension	Combined spring and hydraulic unit
Rollers	
Track rollers (each side)	8
Carrier rollers (each side)	2

Environment

Engine emissions	Fully complies with EU Stage V exhaust emission regulations
Noise levels	
LwA external	104 dB(A) (2000/14/EC Stage II)
LpA operator ear	71 dB(A) (ISO 6396 dynamic test)
Vibration levels (EN 12096:1997)	
Hand/arm	≤ 2.5 m/s ² (uncertainty K = 0.37 m/s ²)
Body	≤ 0.5 m/s ² (uncertainty K = 0.17 m/s ²)
Contains fluorinated greenhouse gas HFC-134a (GWP 1430).	
Quantity of gas 0.8 kg; CO ₂ equivalent 1.14 t	

Operating weight (appr.)

Triple grouser shoes	PC360LCi-11		PC360NLCi-11	
	Operating weight	Ground pressure	Operating weight	Ground pressure
600 mm	35900 kg	0.68 kg/cm ²	35770 kg	0.68 kg/cm ²
700 mm	36280 kg	0.59 kg/cm ²	36150 kg	0.58 kg/cm ²
800 mm	36660 kg	0.52 kg/cm ²	36530 kg	0.52 kg/cm ²
850 mm	36850 kg	0.49 kg/cm ²	-	-

Operating weight, including specified work equipment, 3,2 m arm, 1700 kg bucket, operator, lubricant, coolant, full fuel tank and the standard equipment.

Max. bucket capacity and weight

Arm length	PC360LCi-11		PC360NLCi-11	
	3.2 m		3.2 m	
Material weight up to 1.2 t/m ³	2.66 m ³	1650 kg	2.47 m ³	1575 kg
Material weight up to 1.5 t/m ³	2.29 m ³	1500 kg	2.08 m ³	1425 kg
Material weight up to 1.8 t/m ³	1.90 m ³	1375 kg	1.80 m ³	1300 kg

Max. capacity and weight have been calculated according to ISO 10567:2007.

Please consult with your distributor for the correct selection of buckets and attachments to suit the application.

Bucket and arm force

Arm length	3.2 m
Bucket digging force	21600 kg
Bucket digging force at PowerMax	23200 kg
Arm crowd force	16300 kg
Arm crowd force at PowerMax	17400 kg

Dimensions and performance figures

Machine dimensions	PC360LCi-11	PC360NLCi-11
A Overall width of upper structure	2995 mm	2995 mm
B Overall height (top of cab)	3160 mm	3160 mm
C Overall length of basic machine	5885 mm	5885 mm
D Tail length	3405 mm	3405 mm
Tail swing radius	3445 mm	3445 mm
E Clearance under counterweight	1185 mm	1185 mm
F Machine tail height	3135 mm	3135 mm
G Ground clearance	500 mm	500 mm
H Tumbler centre distance	4030 mm	4030 mm
I Track length	4955 mm	4955 mm
J Track gauge	2590 mm	2390 mm
K Track shoe width	600, 700, 800, 850 mm	600, 700, 800 mm
L Overall track width with 600 mm shoes	3190 mm	2990 mm
Overall track width with 700 mm shoes	3290 mm	3090 mm
Overall track width with 800 mm shoes	3390 mm	3190 mm
Overall track width with 850 mm shoes	3440 mm	-

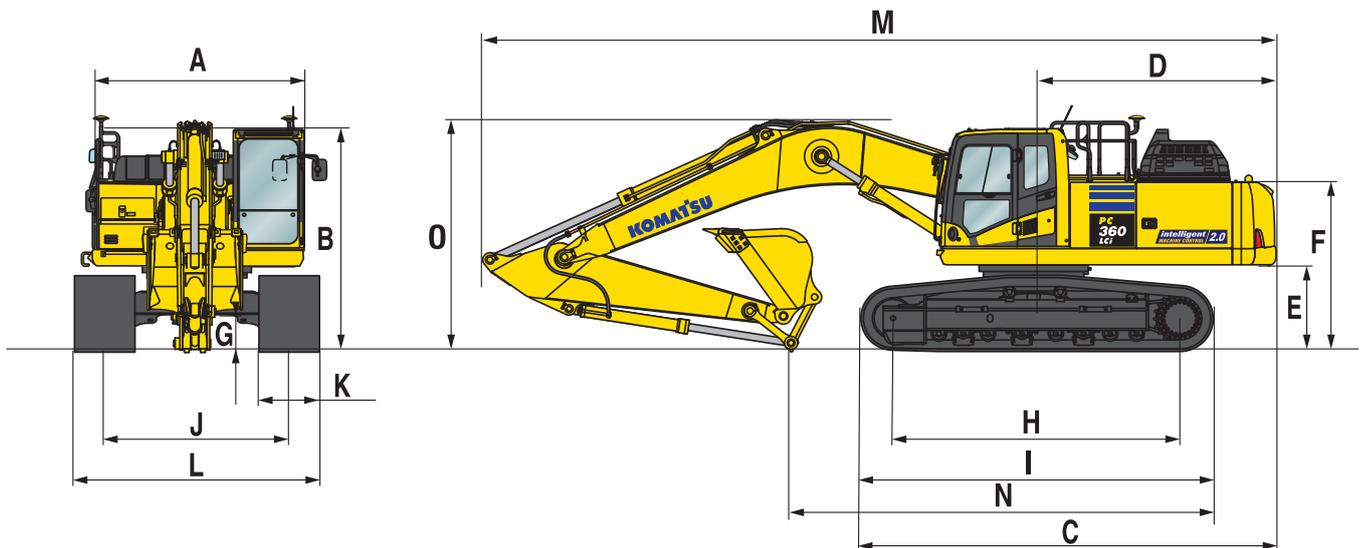

Transport dimensions

Arm length	3.2 m
M Transport length	11145 mm
N Length on ground (transport)	5935 mm
O Overall height (to top of boom)	3365 mm

Working range

Arm length	3.2 m
A Max. digging height	10210 mm
B Max. dumping height	7110 mm
C Max. digging depth	7280 mm
D Max. vertical wall digging depth	6480 mm
E Max. digging depth of cut for 2,44 m level	7180 mm
F Max. digging reach	11100 mm
G Max. digging reach at ground level	10920 mm
H Min. swing radius	4310 mm

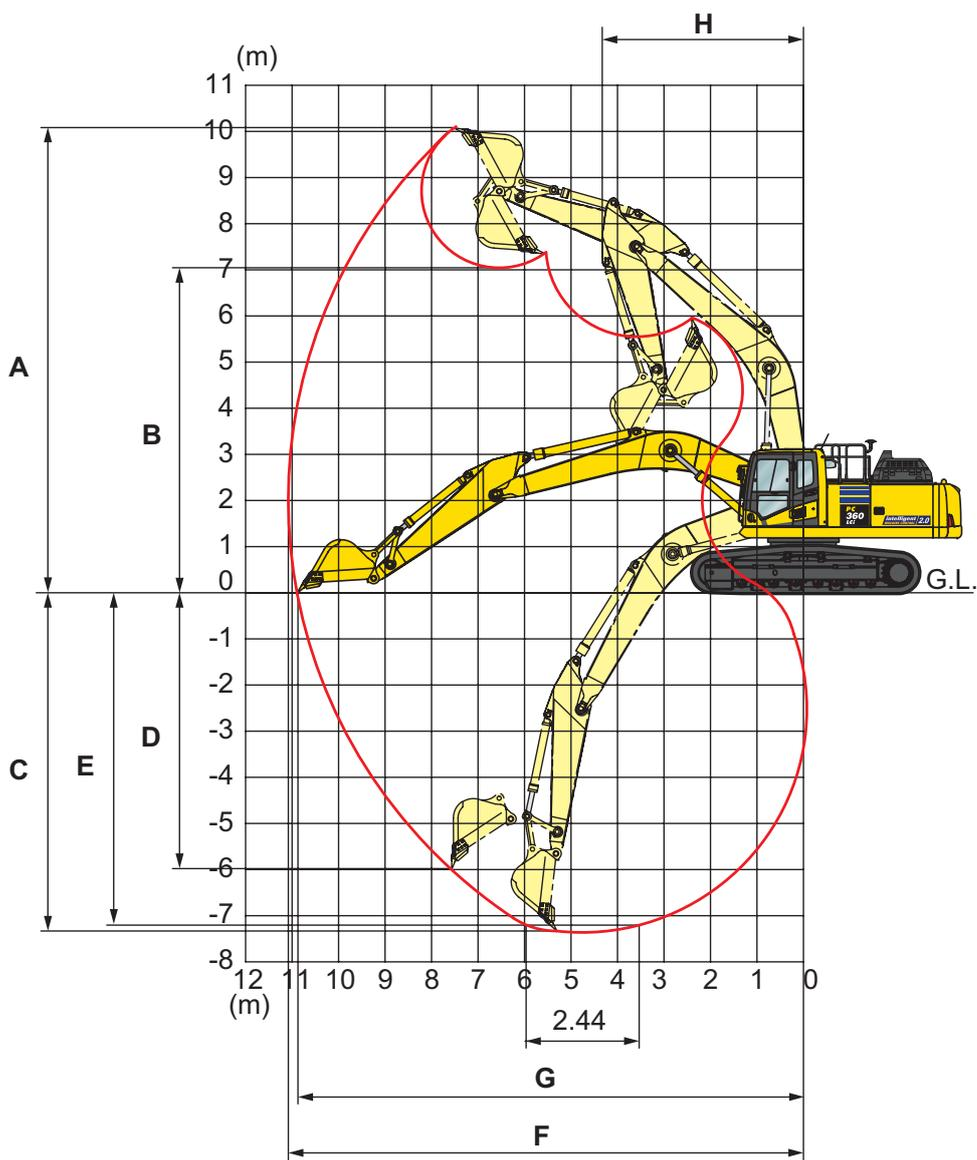

Lifting capacity

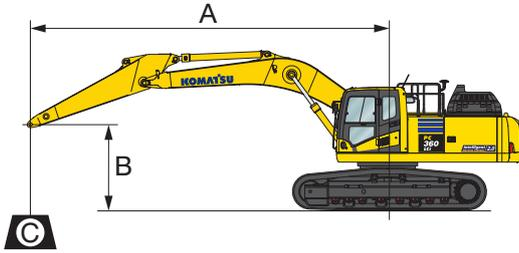

- A** – Reach from swing center
- B** – Bucket hook height
- C** – Lifting capacities

Weights:
 With 3.2 m arm: bucket linkage and bucket cylinder: 435 kg
 With 700 mm shoes

- Rating over front
- Rating over side
- Rating at maximum reach

PC360LCi-11

Arm length	A				9.0 m		7.5 m		6.0 m		4.5 m		3.0 m	
	B													
 3.2 m	6.0 m	kg	6960	6240										
	4.5 m	kg	7030	5570	7650	5640	9270	7440						
	3.0 m	kg	7310	5220	8280	5530	9950	7180	12060	9800	16280	14670		
	1.5 m	kg	7660	5090	8150	5410	10530	6930	13170	9330	18170	13790		
	0.0 m	kg	7830	5180	8050	5320	10370	6740	13660	9040	18460	13420		
	-1.5 m	kg	8390	5520			10280	6660	13400	8920	17600	13360	13300	13300
	-3.0 m	kg	8630	6270			9470	6710	12240	8950	15750	13480	20330	20330
	-4.5 m	kg	8140	7920					9690	9160	12560	12560	15600	15600

PC360NLCi-11

Arm length	A				9.0 m		7.5 m		6.0 m		4.5 m		3.0 m	
	B													
 3.2 m	6.0 m	kg	6960	5740										
	4.5 m	kg	7030	5110	7650	5180	9270	6840						
	3.0 m	kg	7310	4780	8170	5070	9950	6580	12060	8950	16280	13280		
	1.5 m	kg	7550	4660	8030	4950	10430	6330	13170	8500	18170	12430		
	0.0 m	kg	7720	4740	7940	4860	10220	6150	13660	8210	18460	12070		
	-1.5 m	kg	8270	5040			10130	6070	13400	8090	17600	12010	13300	13300
	-3.0 m	kg	8630	5720			9470	6120	12240	8130	15750	12120	20330	20330
	-4.5 m	kg	8140	7230					9690	8340	12560	12420	15600	15600

* Load is limited by hydraulic capacity rather than tipping.

Ratings are based on SAE Standard No. J1097.

Rated loads do not exceed 87% of hydraulic lift capacity or 75% of tipping load.

When lifting with additional equipment installed to the arm, please subtract the weight of all additional equipment from the values stated.

Standard and optional equipment

Engine

Komatsu SAA6D114E-6 turbocharged common rail direct injection diesel engine	●
EU Stage V compliant	●
Suction type cooling fan with radiator fly screen	●
Automatic engine warm-up system	●
Engine overheat prevention system	●
Fuel control dial	●
Auto-deceleration function	●
Adjustable idle shutdown	●
Engine key stop	●
Engine ignition can be password secured on request	●
Alternator 24 V / 90 A	●
Starter motor 24 V / 11 kW	●
Batteries 2 × 12 V / 180 Ah	●

intelligent Machine Control 2.0

Standard factory installed integrated 3D GNSS intelligent Machine Control system	●
Smart Construction Remote	○

Hydraulic system

Electronic closed-centre load sensing (E-CLSS) hydraulic system (HydrauMind)	●
Pump and engine mutual control (PEMC) system	●
6-working mode selection system; Power mode, Economy mode, Breaker mode, Attachment Power and Attachment Economy mode, and Lifting/Fine Operation mode	●
PowerMax function	●
PPC wrist control levers for arm, boom, bucket and swing, with sliding proportional control for attachments and auxiliary buttons	●
Prepared for hydraulic quick-coupler	●
Komatsu Integrated Attachment Control (KIAC)	○
Additional hydraulic functions	○

Undercarriage

Track roller guards	●
Track frame under-guards	●
600, 700, 800, 850 mm triple grouser shoes	○
Full length track roller guards	○

Cabin

Reinforced safety SpaceCab™; highly pressurised and tightly sealed hyper viscous mounted cab with tinted safety glass windows, large roof window with sun shade, pull-up type front window with locking device, removable lower window, front window wiper with intermittent feature, sun roller blind, cigarette lighter, ashtray, luggage shelf, std. floor mat, additional floor mat	●
Heated, high-back air-suspended seat with lumbar support, console mounted height adjustable arm rests, and retractable seat belt	●
Automatic climate control system	●
12 / 24 Volt power supplies	●
USB-A / USB-C power supplies	●
Utility bar	●
Beverage holder and magazine rack	●
Hot and cool box	●
DAB+ radio with Bluetooth®, USB, AUX and hands-free kit	●
Premium comfort seat	○
Lower wiper	○
Rain visor (not with OPG)	○

LED lighting system

Working lights: 2 revolving frame, 1 boom (l.h.)	●
Coming home light function	●
Additional working lights (#1): 2 cab roof (front), 1 cab roof (rear), 1 boom (r.h.), 1 counterweight, beacon	○
Additional working lights (#2): 4 cab roof (front), 1 cab roof (rear), 1 boom (r.h.), 1 counterweight, 2 boom cylinders, 2 revolving frame (l.h. + r.h.), beacon	○

Safety equipment

KomVision surround view system	●
Electric horn	●
Overload warning device	●
Audible travel alarm	●
Boom safety valves	●
Large handrails	●
Rear-view mirrors (for cab adjustable without tools)	●
Battery main switch	●
ROPS compliant to ISO 12117-2:2008	●
Emergency engine stop switch	●
Seat belt caution indicator	●
Neutral position detection system	●
Arm safety valve	●
OPG Level II front guard (FOPS), hinged type	○
OPG Level II front guard (FOPS)	○

Drives and brakes

Hydrostatic, 3-speed travel system with automatic shift and planetary gear type final drives, and hydraulic travel and parking brakes	●
PPC control levers and pedals for steering and travel	●

Service and maintenance

Automatic fuel line de-aeration	●
Double element type air cleaner with dust indicator and auto dust evacuator	●
Komtrax – Komatsu wireless monitoring system (4G)	●
Komatsu Care – a maintenance program for Komatsu customers	●
Multifunction video compatible colour monitor with Equipment Management and Monitoring System (EMMS) and efficiency guidance	●
Toolkit	●
Service points	●
Automatic greasing system	○

Work equipment

Mono boom	●
3.2 m arm	●
Tilt bucket preparation including quick release electrical connection on arm	●
IMU Sensor kit for tilt bucket integration	○
Bucket linkage with lifting eye	○
Komatsu buckets	○
Komatsu breakers	○

Other equipment

Standard counterweight	●
Remote greasing for swing circle and pins	●
Electric refuelling pump with automatic shut-off function	●
Biodegradable oil for hydraulic system	○
Customised paint	○

Further equipment on request

- standard equipment
- optional equipment



A wide range of buckets and attachments is available. Your Komatsu distributor is ready to assist you with the selection of suitable options.

This specification sheet may contain attachments and optional equipment that are not available in your area. Please consult your local Komatsu distributor for those items you may require.

Materials and specifications are subject to change without notice.

Your Komatsu partner:

KOMATSU

[komatsu.eu](https://www.komatsu.eu)

